

METRIC TRAPEZOIDAL SCREW JACKS

The ActionJac™ Trapezoidal Screw Jacks utilize the same rugged design as the ActionJac™ machine screw jacks. These true metric jacks include a lift shaft with a special trapezoidal thread form. This thread form has been created to stay within ISO standards yet retains the centralizing feature of our 2C acme threads. These jacks may be assembled with IEC motor mounts.

See the technical introduction at the beginning of this section for additional Trapezoidal Screw Jack features and comparison to Ball Screw Jacks.



Download Accurate Moveable Assembly 3D Models and 2D Drawings

For ActionJac™ Worm Gear Screw Jacks:

- Configure specific requirements for your Worm Gear Screw Jack application in a simple interface, including motor adapter, right angle reducer, bellows boots and limit switch accessories.
- View complete assemblies on-line with zoom, pan and rotate capabilities.
- Download true assembly models with full range of motion in native AutoCAD®, SolidWorks®, Pro/E®, CATIA®, ParaSolids®, SAT® and many other formats.
- Order complete jack assemblies with generated part number.



FU IBERICA, S.L.U.
TRANSMISION DE POTENCIA

Tel. (+34)+34 932 681 833

Fax (+34)+34 932 683 292

<http://www.fuiberica.com>
fuiberica@

JACK SIZES					JACK SELECTION								Page Ref
MODEL	Capacity (kN)	Lifting Screw Dia. (mm)	Screw Lead (mm)	Root Dia. (mm)	Gear Ratio	Raise for One Turn of Worm (mm)	Maximum Input Torque (N·m)	Maximum Allowable Input (kW)	Max. Worm Speed at Rated Load (rpm)	Maximum Load at 1425 RPM (kN)	Torque to Raise 1 kN (N·m)	No Load Torque (N·m)	
EM05-MSJ	5	16	4	10.9	5:1	0.80	2.25	0.27	1130	4.0	0.45	0.11	359
					20:1	0.20	0.94	0.13	1130	4.6	0.19	0.11	359
EM1-MSJ	10	20	4	14.9	5:1	0.80	5.19	0.36	665	4.7	0.52	0.34	360
					20:1	0.20	2.44	0.19	730	5.1	0.24	0.34	360
EM2.5-MSJ	25	26	6	17.8	6:1	1.0	14.9	1.51	975	17.0	0.59	0.56	361
					12:1	0.5	8.7	1.13	1235	21.7	0.35	0.56	361
					24:1	0.25	6.3	0.38	575	10.1	0.25	0.56	361
EM5-MSJ	50	40	7	30.9	6:1	1.17	40.3	1.87	445	15.6	0.81	1.13	362
					24:1	0.29	16.0	0.51	300	10.7	0.32	1.13	362
EM10-MSJ	100	55	12	40.0	8:1	1.50	97.2	3.65	360	25.2	0.97	2.26	363
					24:1	1.50	215	5.60	250	14.8	0.50	2.26	363
EM20-MSJ	200	65	12	50.0	8:1	1.50	215	5.60	250	35.0	1.08	4.52	364
					24:1	0.50	108	1.9	165	23.0	0.54	4.52	364

NOTES:

- 1) The recommended maximum speed is 1800 RPM providing the recommended horsepower and temperature are not exceeded.
- 2) Input torque is shown as torque to lift one kN of load. Starting Torque is 100% greater than torque shown. For loads less than 25% of rated loads add tare drag torque.
- 3) Maximum allowable power ratings are based on a 25% duty cycle. For operation at higher duty cycles or repeated use over any segment of the total travel, temperature must be monitored and remain less than 95°C.
- 4) Overload capacity of the Trapezoidal Screw Jack is as follows: 10% for dynamic loads, 30% for static loads.
- 5) Trapezoidal Screw Jacks having gear ratios between 20:1 and 32:1, are self-locking and will hold loads without backdriving in the absence of vibrations. All other ratios may require a brake to prevent backdriving.
- 6) All units are suitable for intermittent operation providing that the housing temperature including ambient is not lower than -30°C. or higher than +95°C. Factory supplied grease in standard units will operate in this range. For higher or lower operating temperature ranges consult Nook Industries.

7) Accessories such as boots, limit switches, top plates and clevises are available.

8) Catalog dimensions are representative only and are subject to change without notice. For construction, use only certified prints.

9) Units are not to be used as personnel support or movement.

10) End-of-travel stops are not provided.

$$\text{kW per jack} = \frac{\text{Torque to raise one kN(N·m)} \times \text{Number of kN to be raised} \times \text{RPM}}{9,549}$$

Starting torque is 100% greater than torque shown.

* No load torque need only be added if operating under 25% rated load.

Column strength is the ability of the lift shaft to hold compressive loads without buckling. With longer screw lengths, column strength may be substantially lower than nominal jack capacity.

If the lift shaft is in tension only, the screw jack travel is limited by the available screw material or by the critical speed of the screw. Refer to the trapezoidal screw technical section for critical speed limitations. If there is any possibility for the lift shaft to go into compression, the application should be sized for sufficient column strength.

The chart below is used to determine the required jack size in applications where the lift shaft is loaded in compression.

To use this chart:

Find a point at which the maximum length “L” intersects the maximum load. Be sure the jack selected is above and to the right of that point.

CAUTION: chart does not include a design factor.

The chart assumes proper jack alignment with no bending loads on the screw. Effects from side loading are not included in this chart. Jacks operating horizontally with long lift shafts can experience bending from the weight of the screw. Consult Nook Industries, Inc. if side thrust is anticipated, operating horizontally, or maximum raise is greater than 30 times the screw diameter.

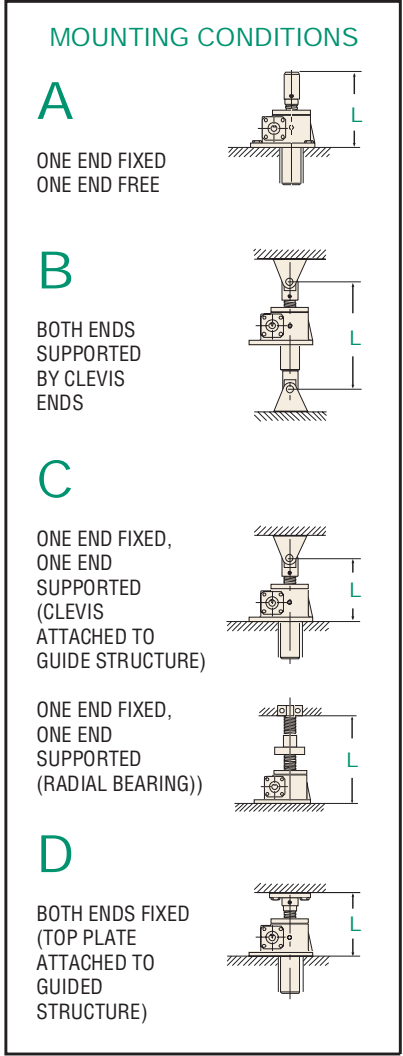
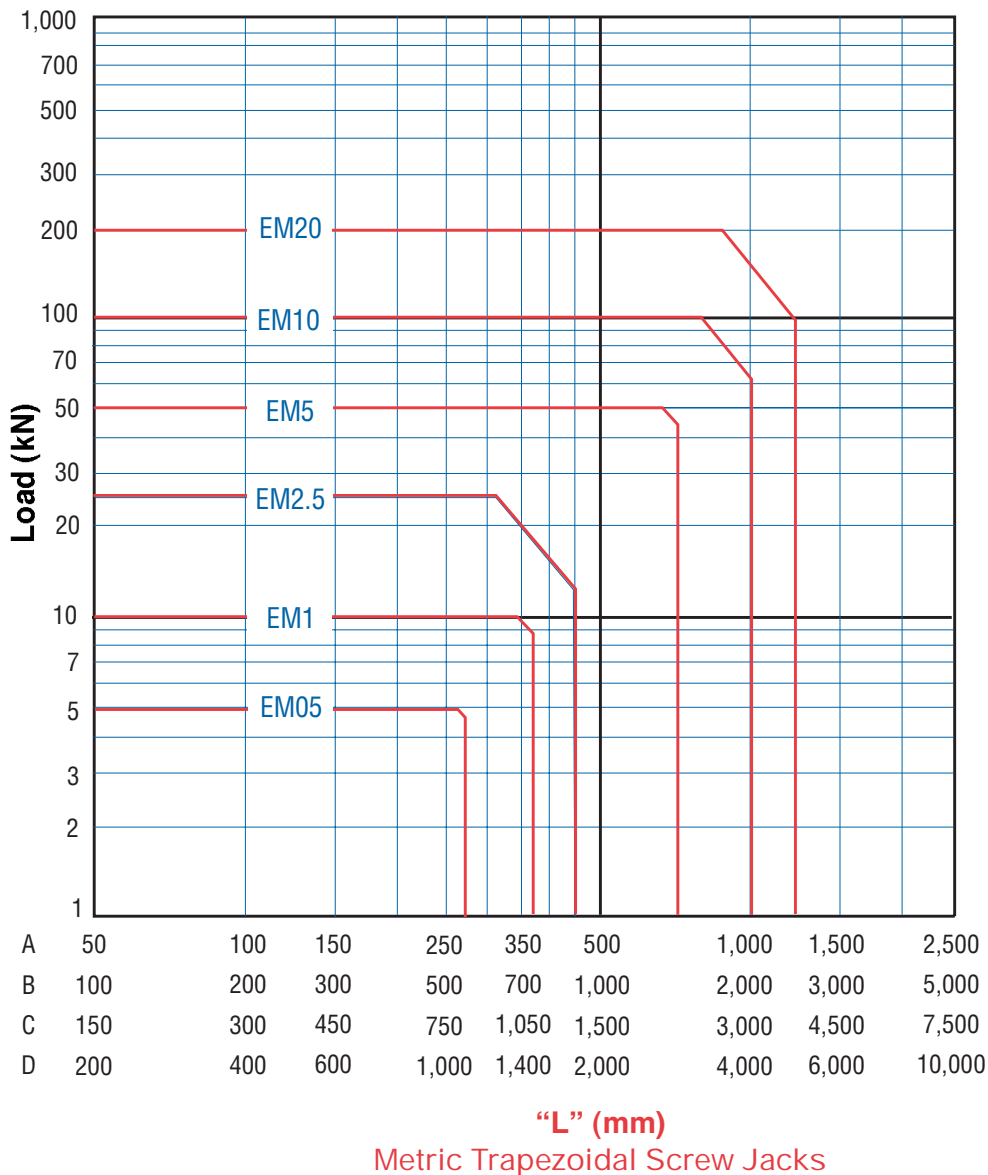

AVAILABLE LIFT SCREW LENGTHS

As a major manufacturer of industrial lead screws, Nook Industries stocks a broad selection of trapezoidal screws. Nook Industries has the capacity to make long trapezoidal

screws for special applications. Rotating screw jacks can be built with a larger diameter lift shaft for greater column strength.

EM2.5-MSJ- U 6:1 / SSE-1 / 80B5-2 / FT / 580mm / SB

TRAPEZOIDAL SCREW MODEL

kN	Model #	kN	Model #
5	= EM05-MSJ	50	= EM5-MSJ
10	= EM1-MSJ	100	= EM10-MSJ
25	= EM2.5-MSJ	200	= EM20-MSJ

CONFIGURATION

- U = Upright
- I = Inverted
- UR = Upright Rotating
- IR = Inverted Rotating

GEAR RATIO

Refer to product pages for available ratios.

SHAFT ORDER CODE

- CCW Position 1
- CW Position 2

ORDER CODES (Must Include A Position)

NO ACCESSORY

- SSE-__ = Standard Shaft Extension, Position 1 or 2
- 000-__ = Delete Shaft Extension, Position 1 or 2
- SPC-__ = Special Modified Shaft Extension, Position 1 or 2

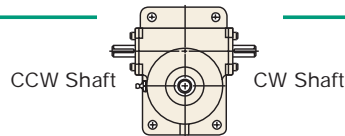

Motor Mounts Without Motor (Position 1 or 2)

56B5 = EM05	80B5 = EM2.5 and EM5
56B14 = EM05	80B14 = EM2.5 and EM5
63B5 = EM1	90B5 = EM5 and EM10
63B14 = EM1	90B14 = EM5 and EM10
71B5 = EM1 and EM2.5	100B5 = EM10 and EM20
71B14 = EM1 and EM2.5	100B14 = EM10 and EM20

NOTE: Both Shaft Extensions Must Be Specified

HOUSING CONFIGURATION

- F = Standard Flange Base

SCREW CONFIGURATION

TRANSLATING - U and I MODELS

- T = Standard Threaded End
- C = Clevis End
- P = Top Plate

ROTATING - UR and IR MODELS

- A = Travel Nut Position "A"
- B = Travel Nut Position "B"

UR - Upright Rotating IR - Inverted Rotating

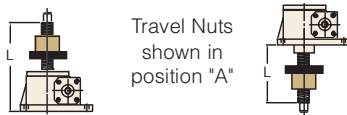

TRAVEL

For Translating Screw Models (U and I) use actual Travel in mm. For Rotating Screw Models (UR and IR) use "L" Dimension in Inches.

MODIFIER LIST

S or M Required

- S = Standard, no additional description required
- M = Modified, additional description required

E and/or B Optional

- E = In-Line Encoder (motor or motor mount required)
- B = Bellows Boots (must calculate retracted and extended boot length, see page 280-281)

EM05 MSJ Housing Top View

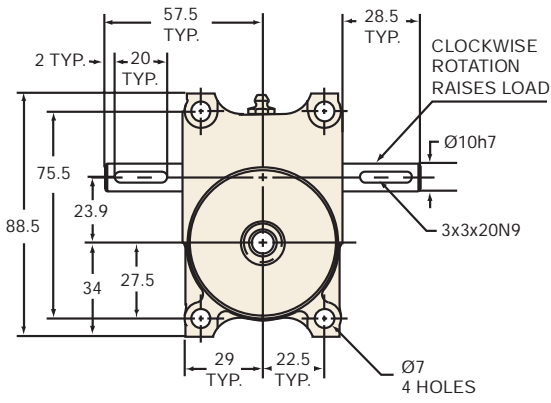

EM05-MSJ-U (Upright)

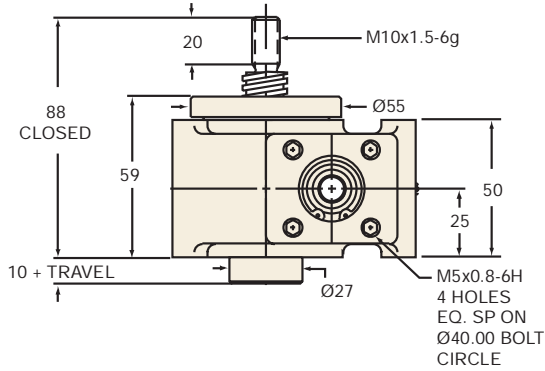

EM05-MSJ-I (Inverted)

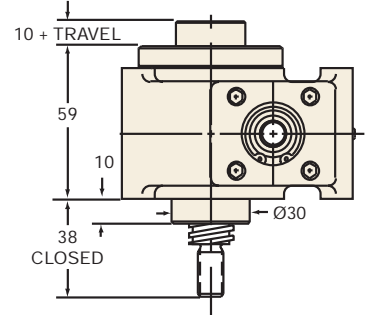

EM05-MSJ-UR (Upright Rotating)

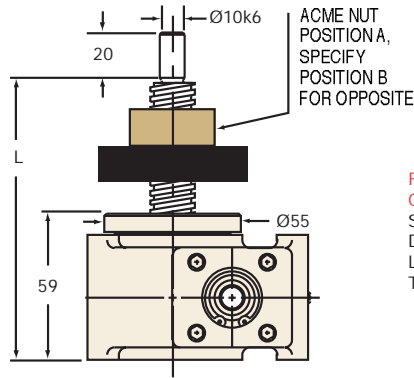

FOR ORDERING SPECIFY "L" DIMENSION
L (min) = TRAVEL + 111

EM05-MSJ-IR (Inverted Rotating)

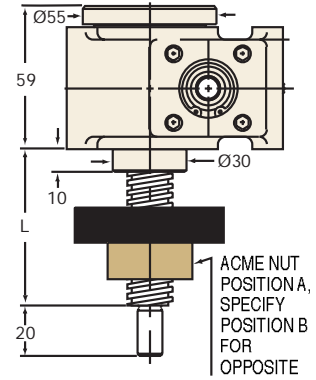

FOR ORDERING SPECIFY "L" DIMENSION
L (min) = TRAVEL + 61

TOP PLATE (optional): 9000-EM-12

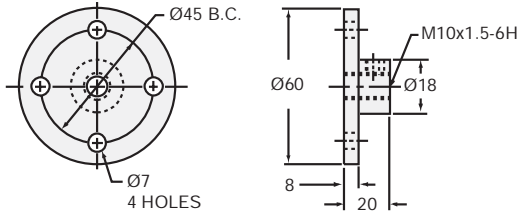

CLEVIS END (optional): 9001-EM-12

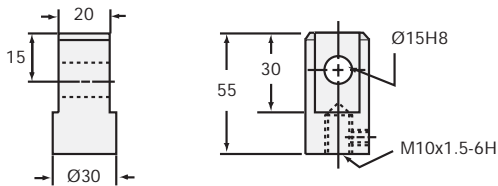

MOTOR MOUNTS

see page 277

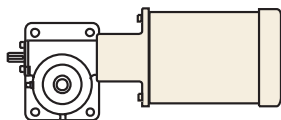

ACME NUT & FLANGE DIMENSIONS

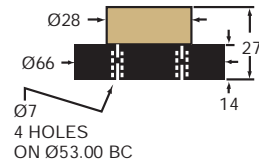

EM05-MSJ SCREW

SCREW:	Tr16x4
ROOT DIAMETER:	10.9
DRAG TORQUE:	0.11
START TORQUE:	2 x Running Torque
WEIGHT (Approx. in Kg)	
"0" TRAVEL:	1.13
PER 100mm TRAVEL:	0.12
GREASE:	0.23

RATIO	TRAVEL PER 1 TURN OF WORM	TORQUE TO RAISE ONE kN NON-KEYED	MAX. kW	MAX. WORM SPEED AT RATED LOAD NON-KEYED	MAX. LOAD AT 1425 RPM NON-KEYED
5:1	0.80 mm	0.45 Nm	0.27	1130 rpm	4.0 kN
20:1	0.20 mm	0.19 Nm	0.13	1300 rpm	4.6 kN

LIFTING SCREW OR NUT MUST BE SECURED TO PREVENT ROTATION FOR NON-KEYED UNITS.
CAUTION! JACK MAY BE SELF-LOWERING IN SOME OPERATING CONDITIONS.

EM1 MSJ Housing Top View

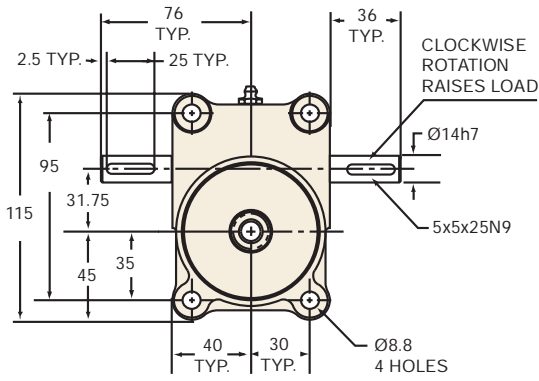

EM1-MSJ-U (Upright)

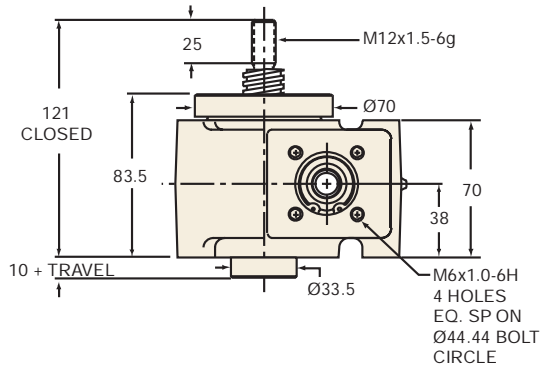

EM1-MSJ-I (Inverted)

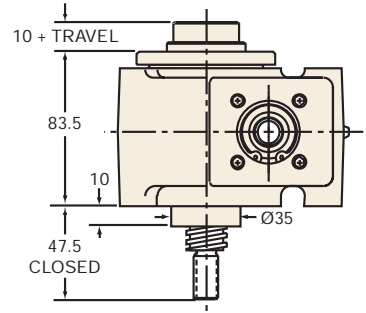

EM1-MSJ-UR (Upright Rotating)

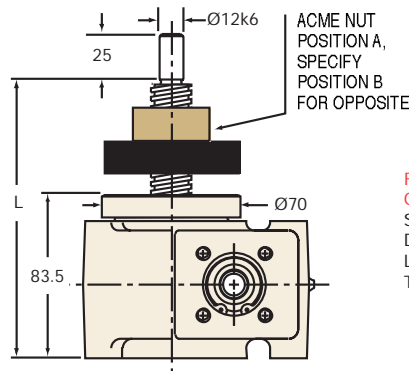

FOR ORDERING SPECIFY "L" DIMENSION
L (min) = TRAVEL + 140

EM1-MSJ-IR (Inverted Rotating)

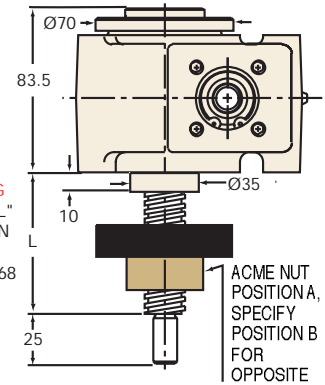

FOR ORDERING SPECIFY "L" DIMENSION
L (min) = TRAVEL + 68

TOP PLATE (optional): 9000-EM-11

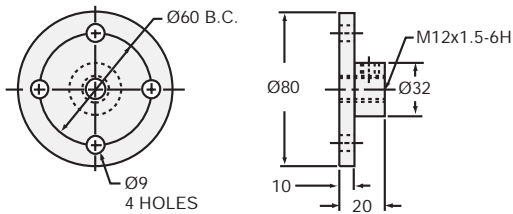

ACME NUT & FLANGE DIMENSIONS

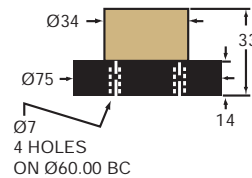

CLEVIS END (optional): 9001-EM-11

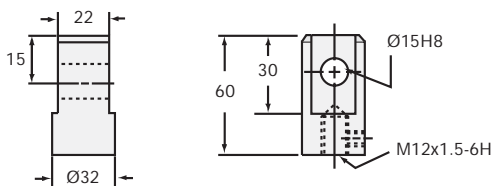

MOTOR MOUNTS

see page 277

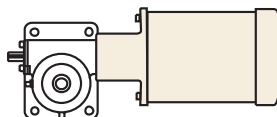

EM1-MSJ SCREW

SCREW:	Tr20x4
ROOT DIAMETER:	14.9
DRAG TORQUE:	0.34
START TORQUE:	2 x Running Torque
WEIGHT (Approx. in Kg)	
"0" TRAVEL:	2.5
PER 100mm TRAVEL:	0.19
GREASE:	0.23

RATIO	TRAVEL PER 1 TURN OF WORM	TORQUE TO RAISE ONE kN NON-KEYED	MAX. kW	MAX. WORM SPEED AT RATED LOAD NON-KEYED	MAX. LOAD AT 1425 RPM NON-KEYED
5:1	0.80 mm	0.52 Nm	0.36	665 rpm	4.7 kN
20:1	0.20 mm	0.24 Nm	0.19	730 rpm	5.1 kN

LIFTING SCREW OR NUT MUST BE SECURED TO PREVENT ROTATION FOR NON-KEYED UNITS.
CAUTION! JACK MAY BE SELF-LOWERING IN SOME OPERATING CONDITIONS.

EM2.5 MSJ Housing Top View

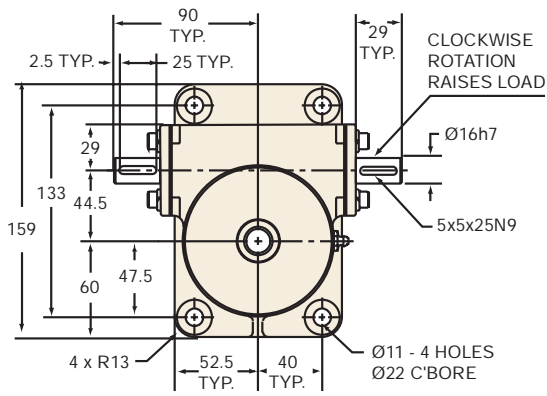

EM2.5-MSJ-U (Upright)

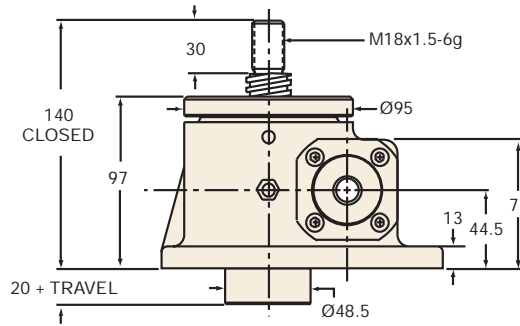

EM2.5-MSJ-I (Inverted)

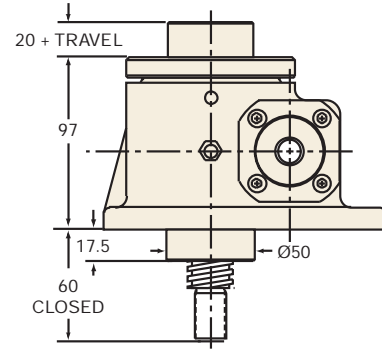

EM2.5-MSJ-UR (Upright Rotating)

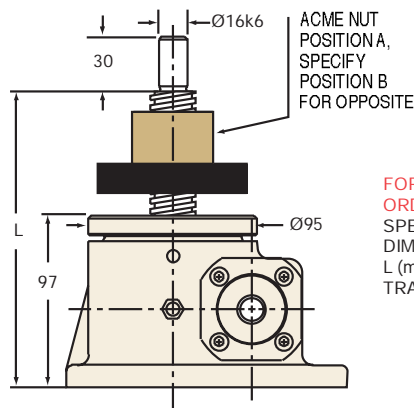

FOR ORDERING SPECIFY "L" DIMENSION
L (min) = TRAVEL + 168

EM2.5-MSJ-IR (Inverted Rotating)

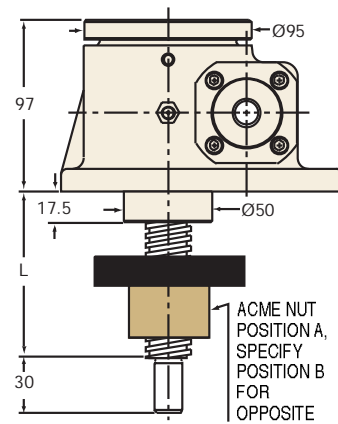

FOR ORDERING SPECIFY "L" DIMENSION
L (min) = TRAVEL + 92

TOP PLATE (optional): 9000-EM-01

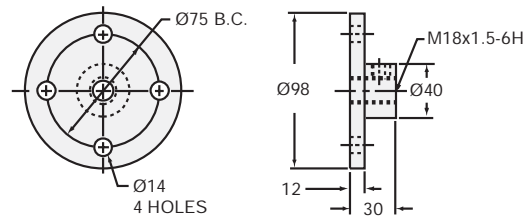

CLEVIS END (optional): 9001-EM-01

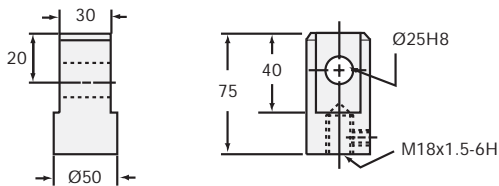

MOTOR MOUNTS

see page 277

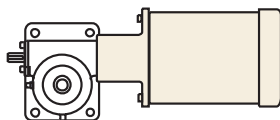

ACME NUT & FLANGE DIMENSIONS

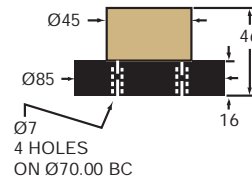

EM2.5-MSJ SCREW

SCREW:	Tr26x6
ROOT DIAMETER:	17.8
DRAG TORQUE:	.56
START TORQUE:	2 x Running Torque
WEIGHT (Approx. in Kg)	
"0" TRAVEL:	7.7
PER 100mm TRAVEL:	0.32
GREASE:	0.22

RATIO	TRAVEL PER 1 TURN OF WORM	TORQUE TO RAISE ONE kN NON-KEYED	MAX. kW	MAX. WORM SPEED AT RATED LOAD NON-KEYED	MAX. LOAD AT 1425 RPM NON-KEYED
6:1	1.0 mm	0.59 Nm	1.51	975 rpm	17.0 kN
12:1	0.5 mm	0.35 Nm	1.13	1235 rpm	21.7 kN
24:1	0.25 mm	0.25 Nm	0.38	575 rpm	10.1 kN

LIFTING SCREW OR NUT MUST BE SECURED TO PREVENT ROTATION FOR NON-KEYED UNITS.
CAUTION! JACK MAY BE SELF-LOWERING IN SOME OPERATING CONDITIONS.

EM5 MSJ Housing Top View

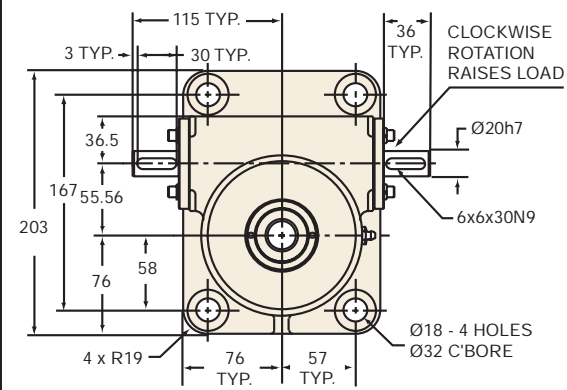

EM5-MSJ-U (Upright)

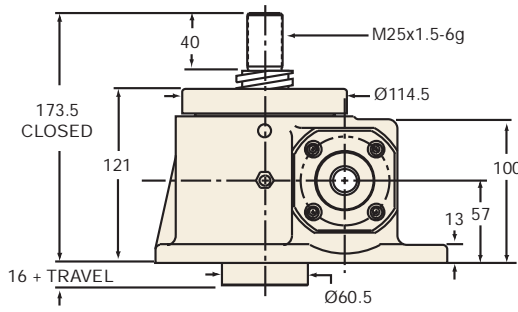

EM5-MSJ-I (Inverted)

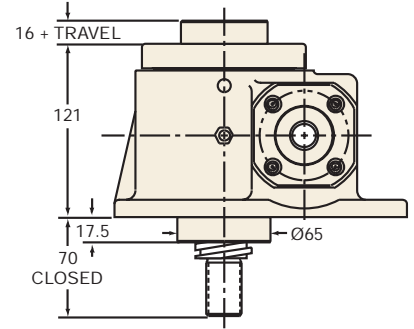

EM5-MSJ-UR (Upright Rotating)

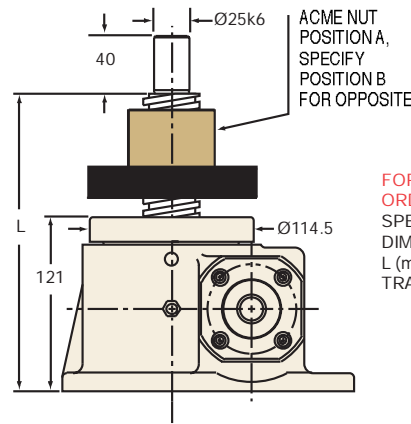

FOR ORDERING SPECIFY "L" DIMENSION
L (min) = TRAVEL + 207

EM5-MSJ-IR (Inverted Rotating)

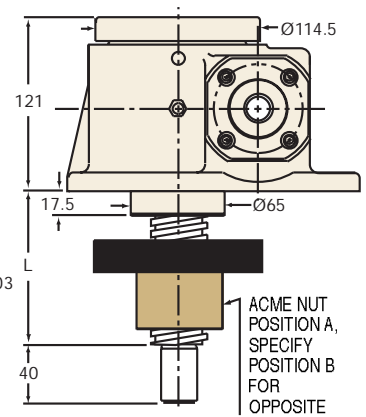

FOR ORDERING SPECIFY "L" DIMENSION
L (min) = TRAVEL + 103

TOP PLATE (optional): 9000-EM-02

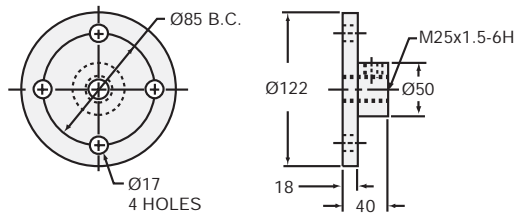

CLEVIS END (optional): 9001-EM-02

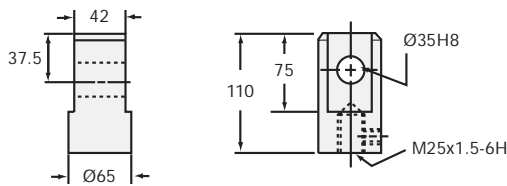

MOTOR MOUNTS

see page 277

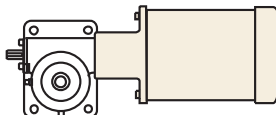

ACME NUT & FLANGE DIMENSIONS

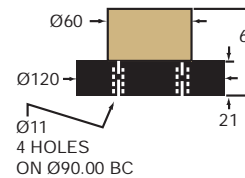

EM5-MSJ SCREW

SCREW: Tr40x7
 ROOT DIAMETER: 30.9
 DRAG TORQUE: 1.13
 START TORQUE: 2 x Running Torque
 WEIGHT (Approx. in Kg)
 "0" TRAVEL: 13.6
 PER 100mm TRAVEL: 0.81
 GREASE: 0.45

RATIO	TRAVEL PER 1 TURN OF WORM	TORQUE TO RAISE ONE kN NON-KEYED	MAX. kW	MAX. WORM SPEED AT RATED LOAD NON-KEYED	MAX. LOAD AT 1425 RPM NON-KEYED
6:1	1.17 mm	0.81 Nm	1.87	445 rpm	15.6 kN
24:1	0.29 mm	0.32 Nm	0.51	300 rpm	10.7 kN

LIFTING SCREW OR NUT MUST BE SECURED TO PREVENT ROTATION FOR NON-KEYED UNITS.
CAUTION! JACK MAY BE SELF-LOWERING IN SOME OPERATING CONDITIONS.

EM10 MSJ Housing Top View

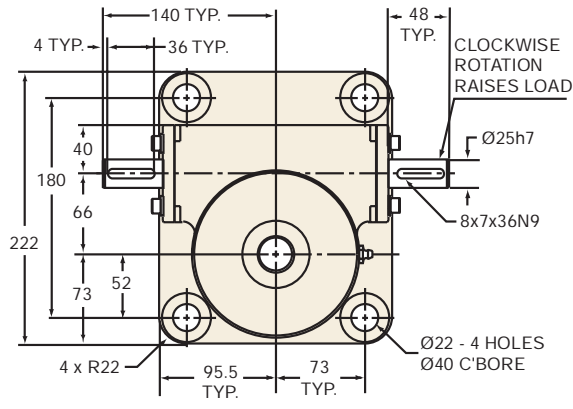

EM10-MSJ-U (Upright)

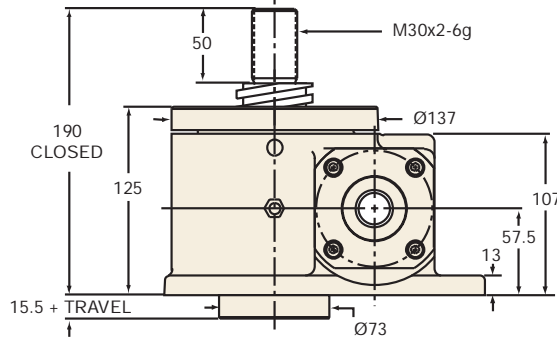

EM10-MSJ-I (Inverted)

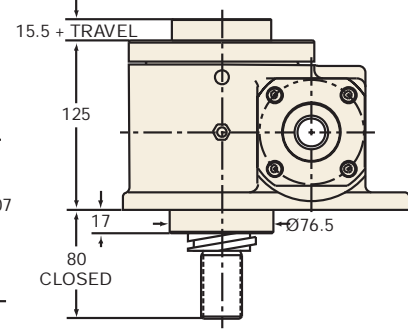

EM10-MSJ-UR (Upright Rotating)

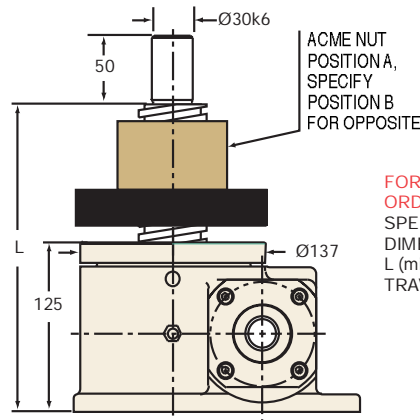

FOR ORDERING SPECIFY "L" DIMENSION
L (min) = TRAVEL + 227

EM10-MSJ-IR (Inverted Rotating)

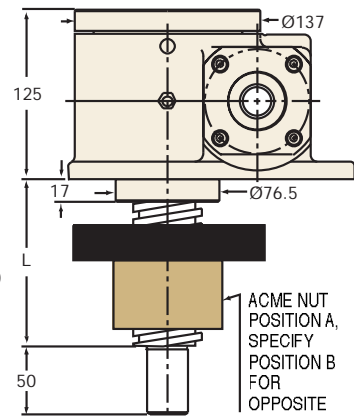

FOR ORDERING SPECIFY "L" DIMENSION
L (min) = TRAVEL + 120

TOP PLATE (optional): 9000-EM-04

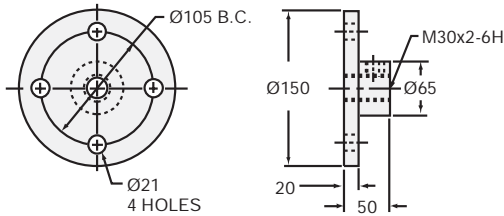

CLEVIS END (optional): 9001-EM-04

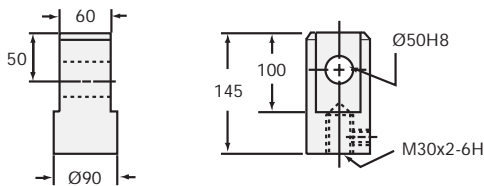

MOTOR MOUNTS

see page 277

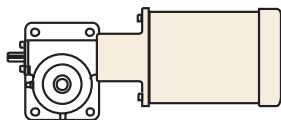

ACME NUT & FLANGE DIMENSIONS

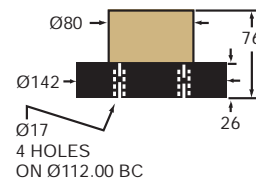

EM10-MSJ SCREW

SCREW:	Tr55x12
ROOT DIAMETER:	40
DRAG TORQUE:	2.26
START TORQUE:	2 x Running Torque
WEIGHT (Approx. in Kg)	
"0" TRAVEL:	20.4
PER 100mm TRAVEL:	1.46
GREASE:	0.68

RATIO	TRAVEL PER 1 TURN OF WORM	TORQUE TO RAISE ONE kN NON-KEYED	MAX. kW	MAX. WORM SPEED AT RATED LOAD NON-KEYED	MAX. LOAD AT 1425 RPM NON-KEYED
8:1	1.5 mm	0.97 Nm	3.65	360 rpm	25.2 kN
24:1	0.5 mm	0.50 Nm	1.10	210 rpm	14.8 kN

LIFTING SCREW OR NUT MUST BE SECURED TO PREVENT ROTATION FOR NON-KEYED UNITS.
CAUTION! JACK MAY BE SELF-LOWERING IN SOME OPERATING CONDITIONS.

EM20 MSJ Housing Top View

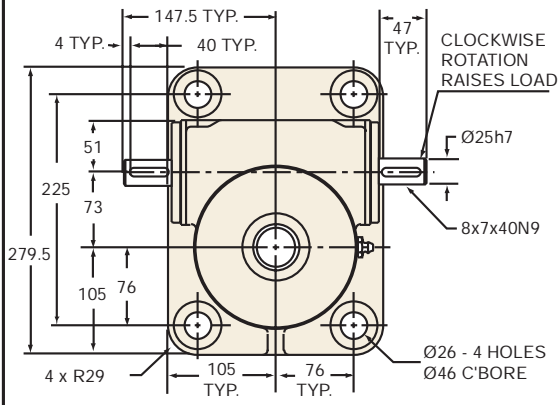

EM20-MSJ-U (Upright)

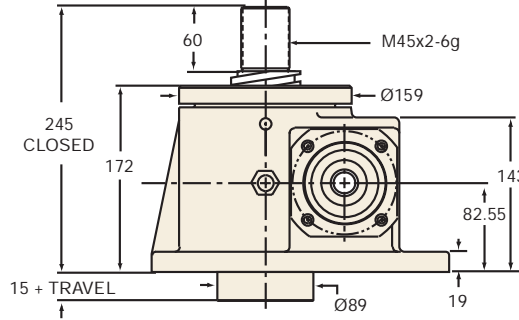

EM20-MSJ-I (Inverted)

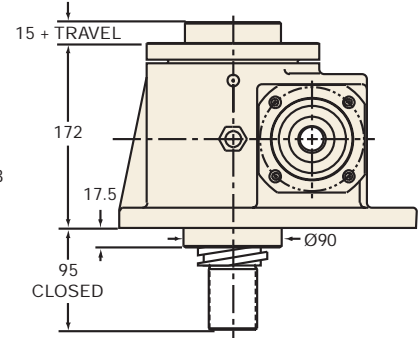

EM20-MSJ-UR (Upright Rotating)

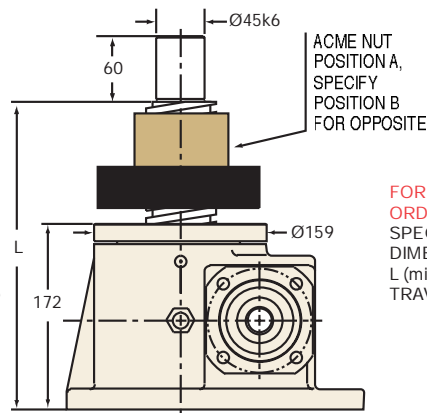

FOR ORDERING SPECIFY "L" DIMENSION
L (min) = TRAVEL + 285

EM20-MSJ-IR (Inverted Rotating)

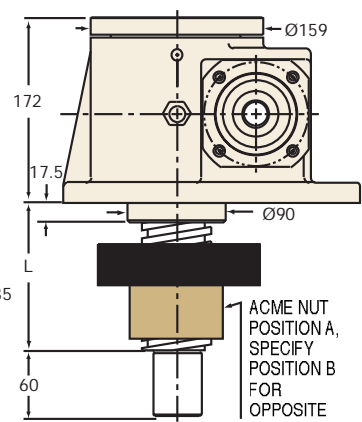

FOR ORDERING SPECIFY "L" DIMENSION
L (min) = TRAVEL + 135

TOP PLATE (optional): 9000-EM-06

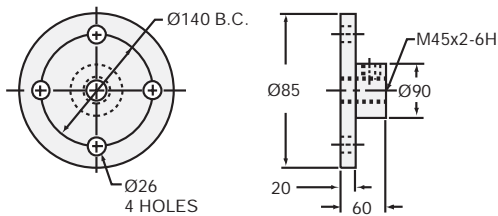

CLEVIS END (optional): 9001-EM-06

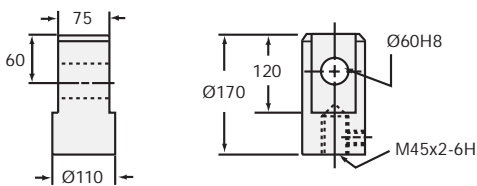

MOTOR MOUNTS

see page 277

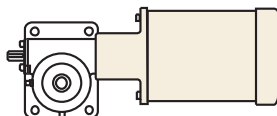

ACME NUT & FLANGE DIMENSIONS

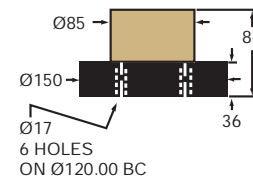

EM20-MSJ SCREW

SCREW:	Tr65x12
ROOT DIAMETER:	50
DRAG TORQUE:	4.52
START TORQUE:	2 x Running Torque
WEIGHT (Approx. in Kg)	
"0" TRAVEL:	36.3
PER 100mm TRAVEL:	2.12
GREASE:	1.0

RATIO	TRAVEL PER 1 TURN OF WORM	TORQUE TO RAISE ONE kN NON-KEYED	MAX. kW	MAX. WORM SPEED AT RATED LOAD NON-KEYED	MAX. LOAD AT 1425 RPM NON-KEYED
8:1	1.50 mm	1.08 Nm	5.6	250 rpm	35.0 kN
24:1	0.5 mm	0.54 Nm	1.9	165 rpm	23.0 kN

LIFTING SCREW OR NUT MUST BE SECURED TO PREVENT ROTATION FOR NON-KEYED UNITS.
CAUTION! JACK MAY BE SELF-LOWERING IN SOME OPERATING CONDITIONS.